

**KAYAK**   
INNOVATIONS



**EN** USER MANUAL

**NATSEQ**

## NATSEQ - your new modular kayak

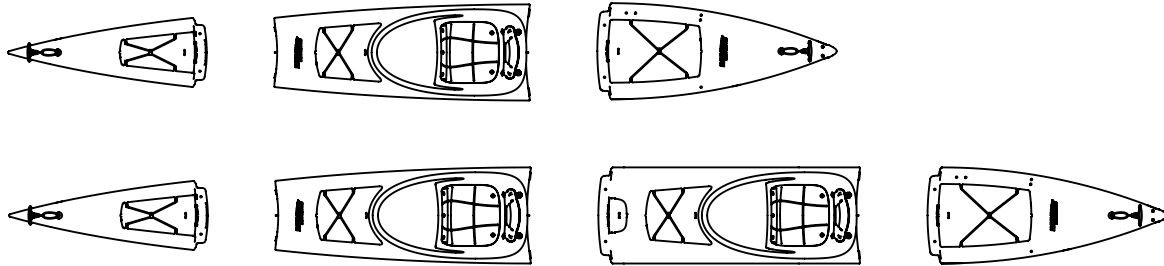

**FOR A LONG SERVICE LIFE OF YOUR BOAT, PLEASE NOTE THE FOLLOWING NOTES:**

### **Cleaning and care**

NATSEQ will last longer if you wash it off with a soft cloth and lukewarm water after use. So pollution and water particles cannot accumulate permanently. After use in salt water, all components, especially the locking mechanisms, must be rinsed with plenty of clear tap water.

### **Maintenance**

Check all screws from time to time. Make sure that the screws are always hand-tightened.

## Mounting

- If possible, always put them together on a level surface
- Not on gravel or split to avoid inclusions
- For easier assembly raise the lower part a little - if necessary place an object underneath (e.g. found wood or paddle shaft)

1.

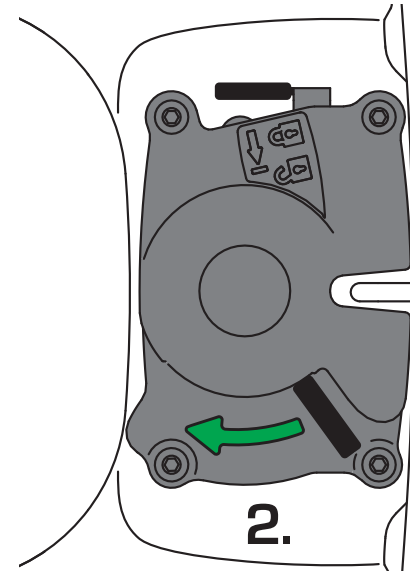
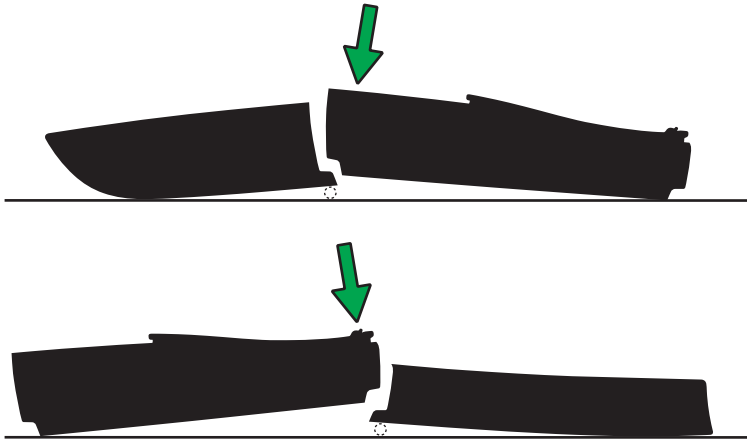

## Dismantling

- If possible, always on level ground
- For easier dismantling lift the upper part a little and put an object underneath (e.g. found wood or paddle shaft)

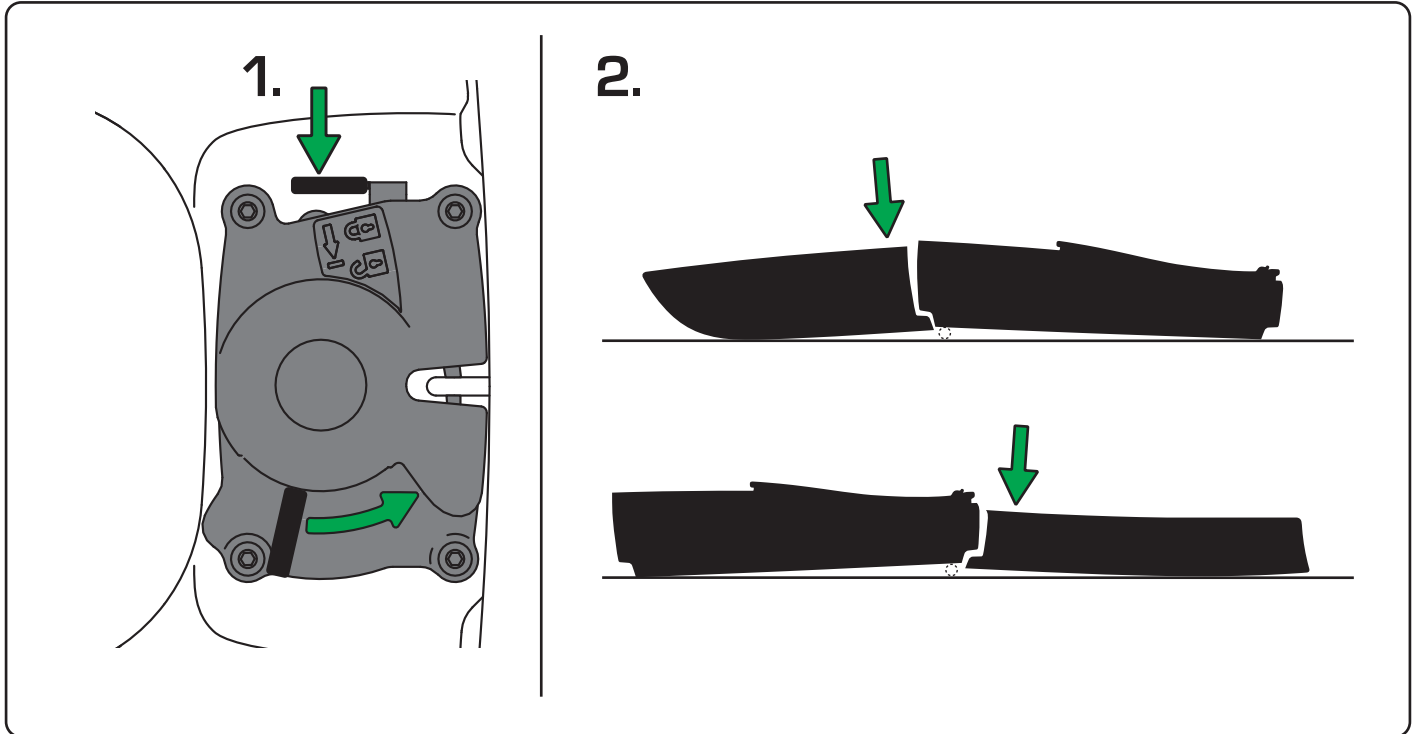

### Adjustable backrest

Stepless positioning of the backrest

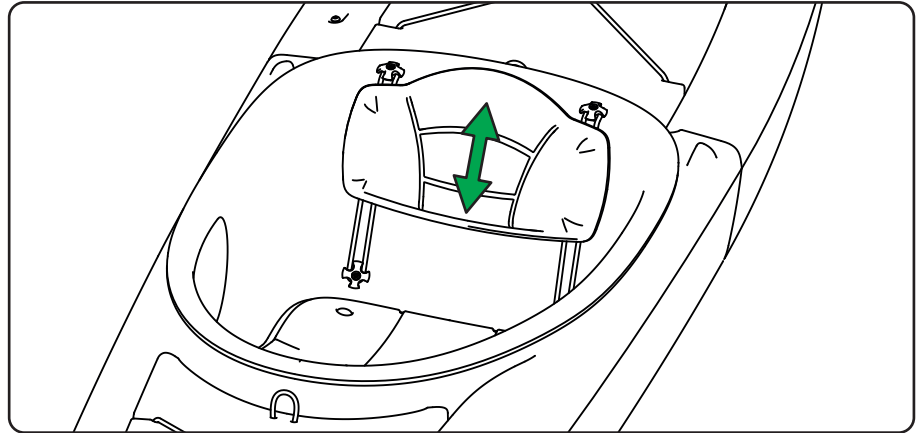

### Adjustment of the footrests

Turn the handlebars upwards, adjust the length and lock again

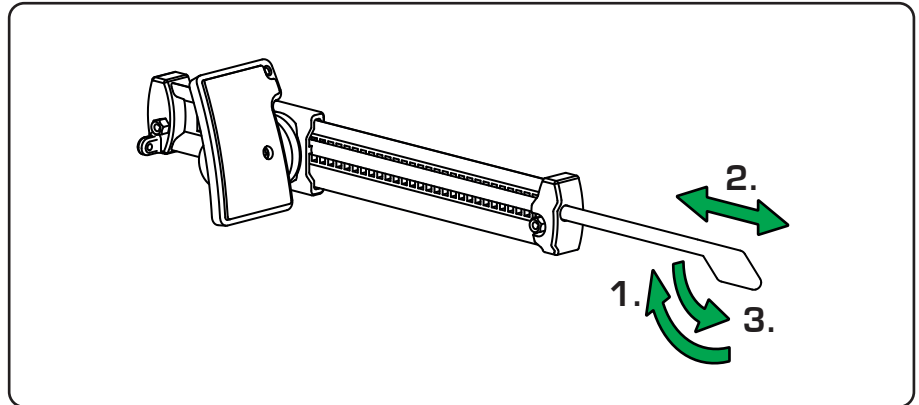

## Steering system - Mounting rudder blade

Swivel the rudder blade 90° to the left, insert it into the holder at the rear from above and then turn it back to a straight position

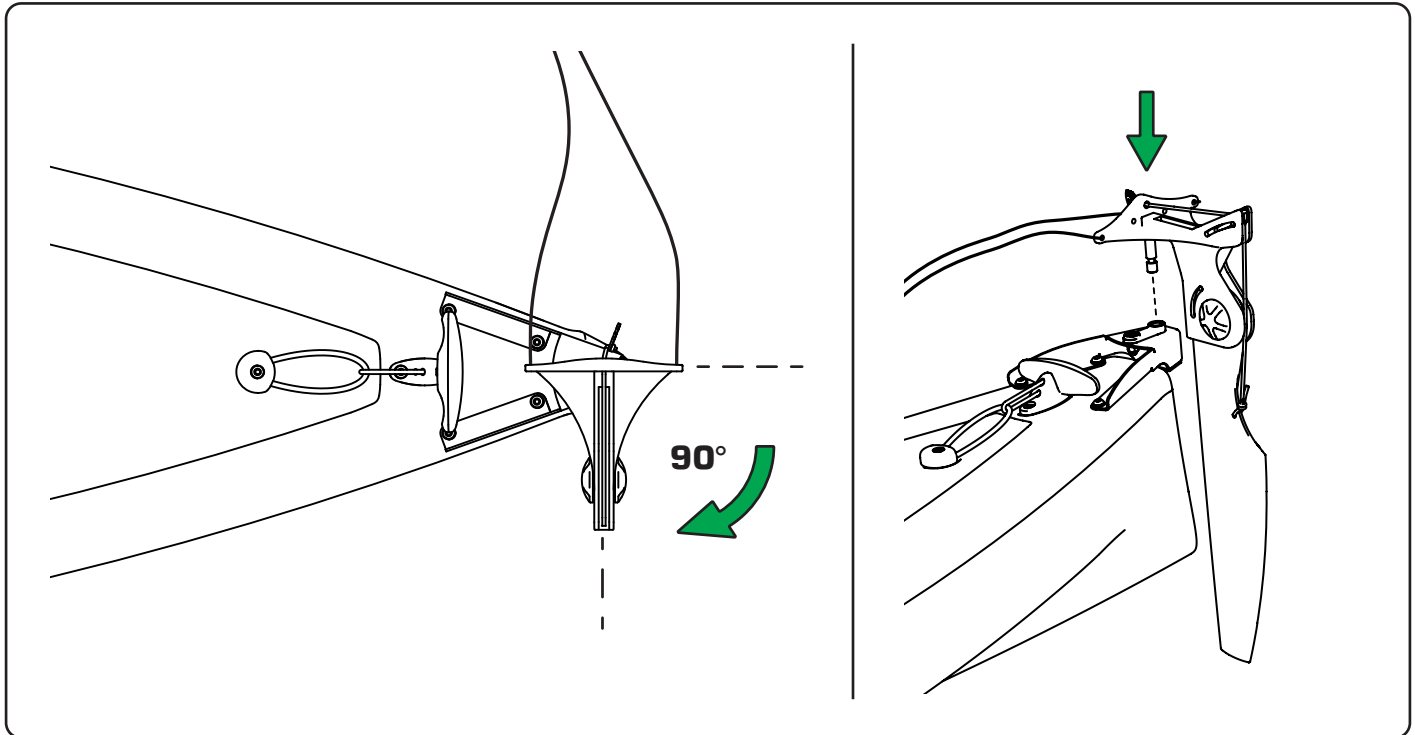

## Steering system - assembly of steering and pulley ropes

(A) Guide the control lines through the line connectors on the left and right and tighten using a loop, (B) put the lines around the deck fittings and (C) readjust using the line tensioner (D) Feed the pulley rope through the line connector on the control blade and fasten it with a loop

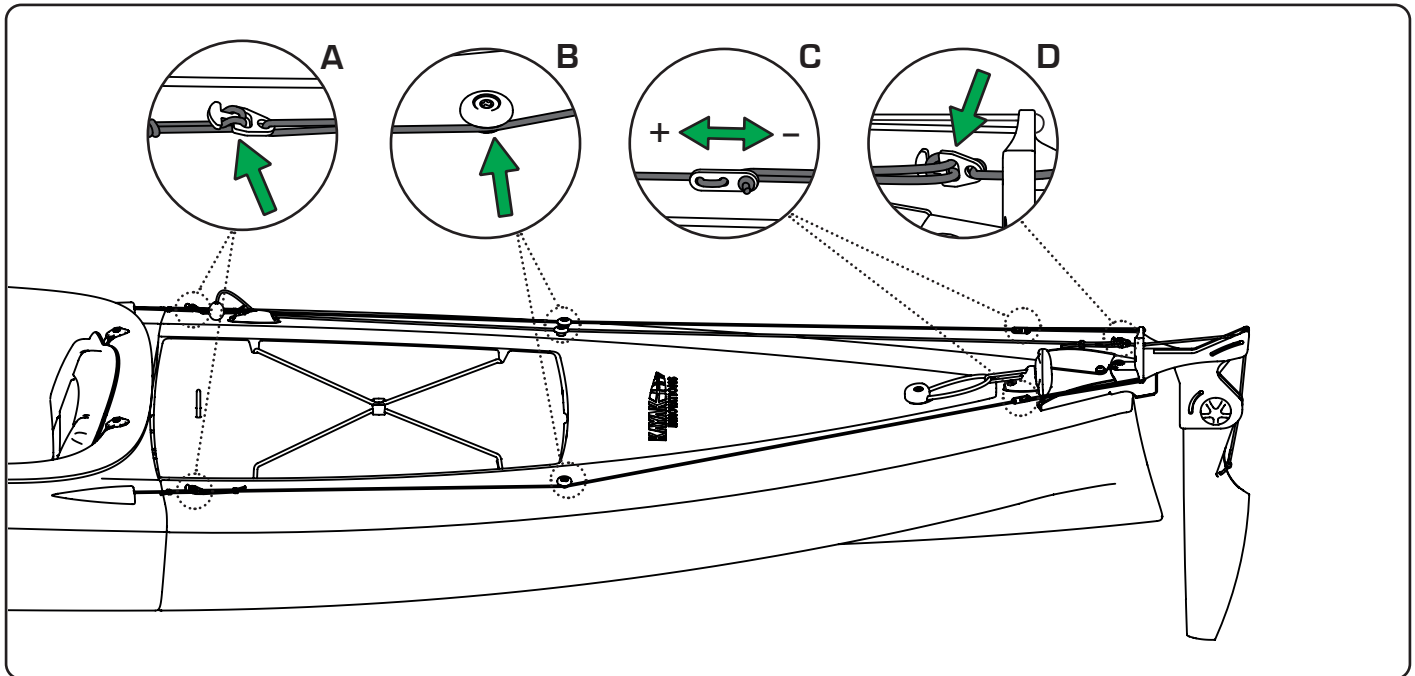

## Steering system - Functions

Controlling the rudder and changing course with the foot pedals:

- To starboard - right pedal
- To port - left pedal

The position of the pedal can be adjusted at any time and does not affect the tension in the steering lines.

The steering blade is set down and picked up by pulling the ball handle of the pull-up cord.

**Make sure there is sufficient water depth when the rudder blade is lowered!**

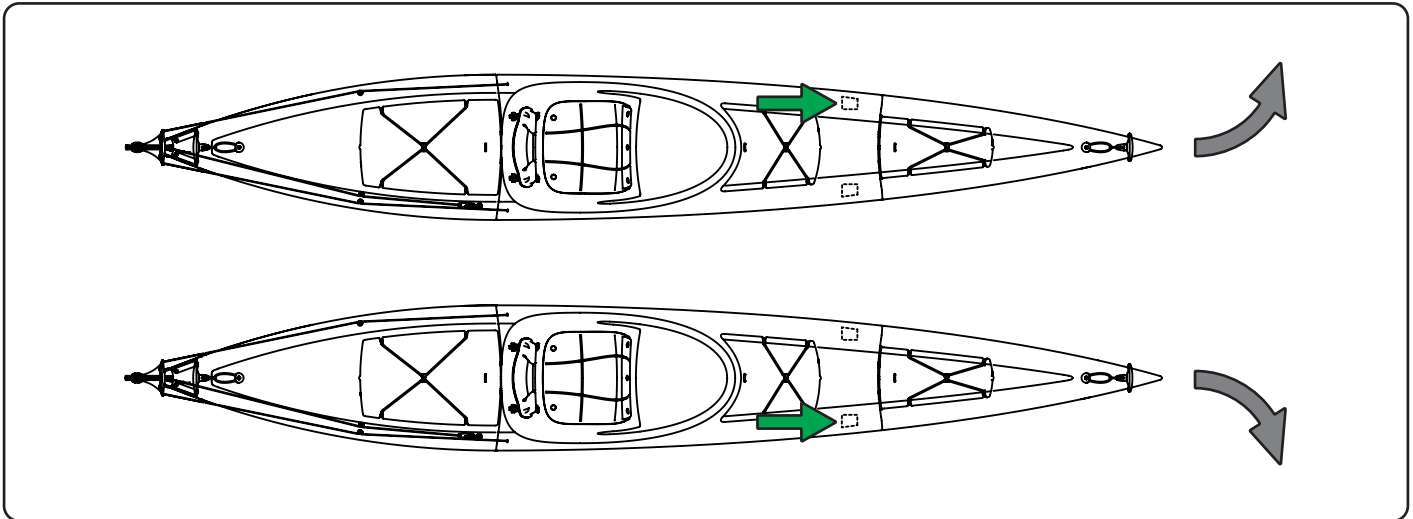



## Control system - dismantling for transport

- Unhook the steering lines and stow them in the cockpit
- Loosen the pulley rope and lay it on deck as shown
- Turn the rudder blade 90 ° to the left and remove it

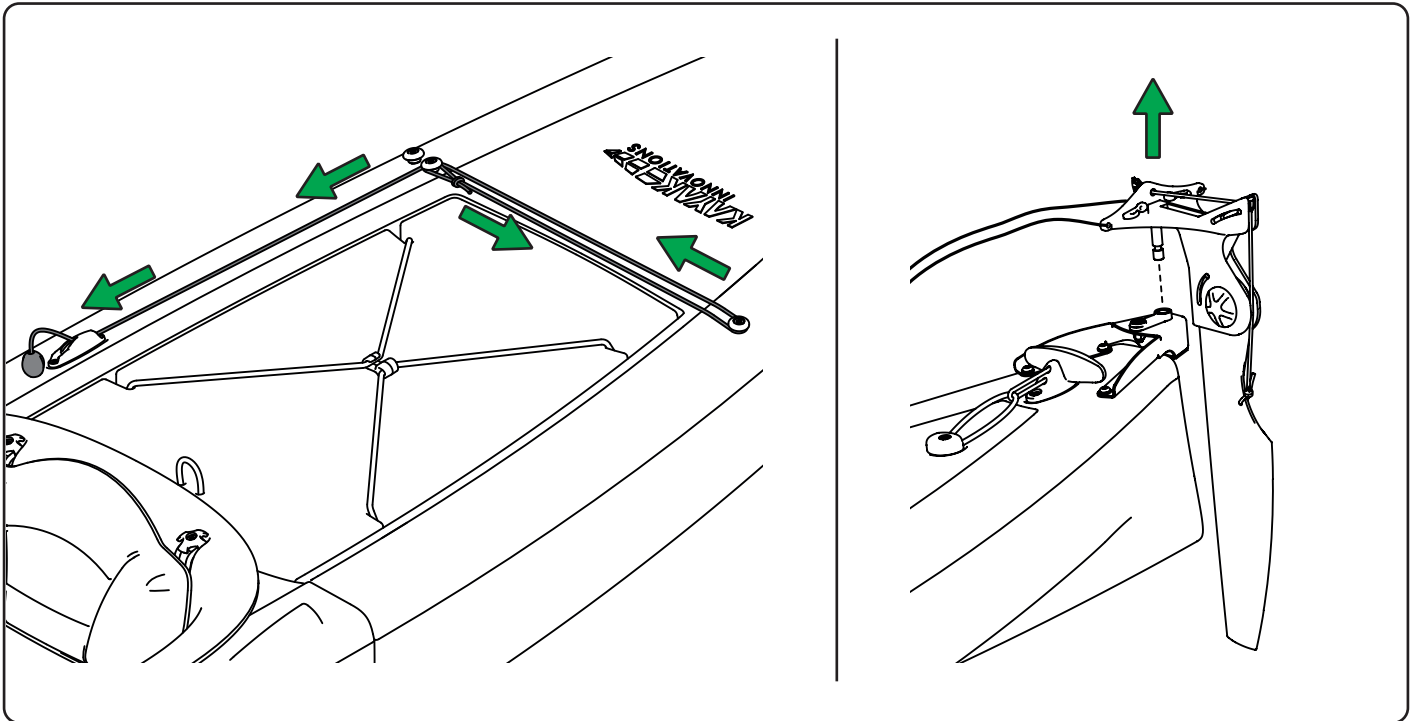

## Avoid damage when getting in and out

- Please get in and out when the water is at least 10 cm deep
- Please no “seal launches” or “seal landings” caused by drifting onto and off the bank, especially on stony banks

This way you avoid plastic abrasion. Your boat and nature will thank you!

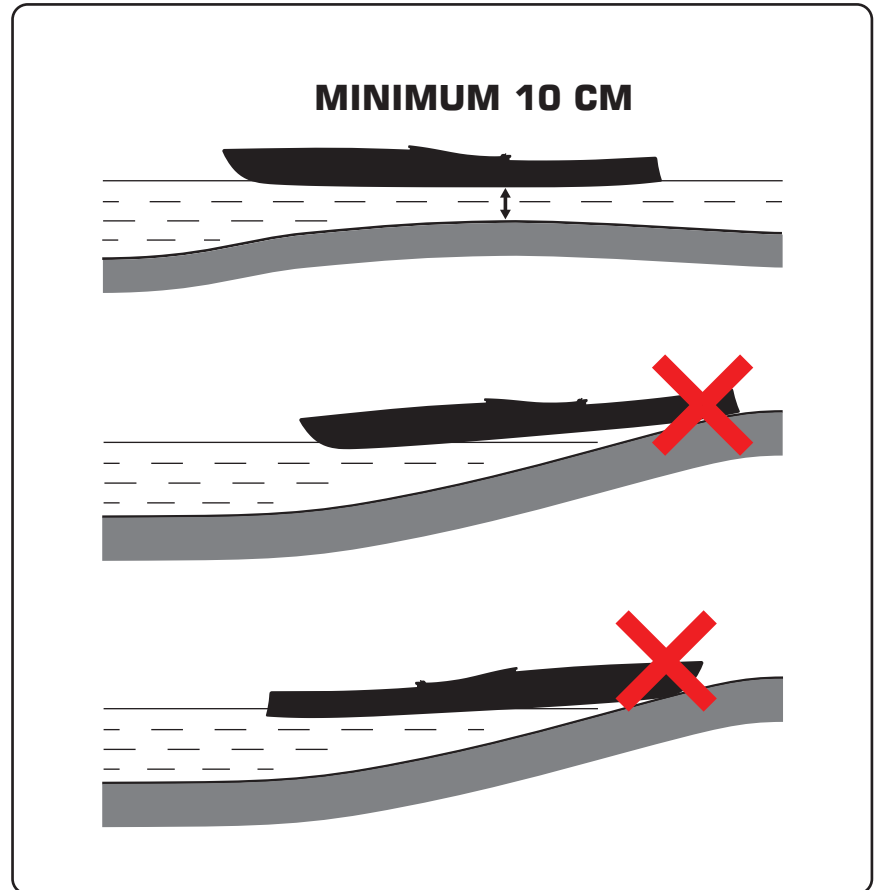

## Carrying the boat

- Only carry NATSEQ assembled when it is empty
- For longer stretches on land, dismantle the kayak into its individual segments

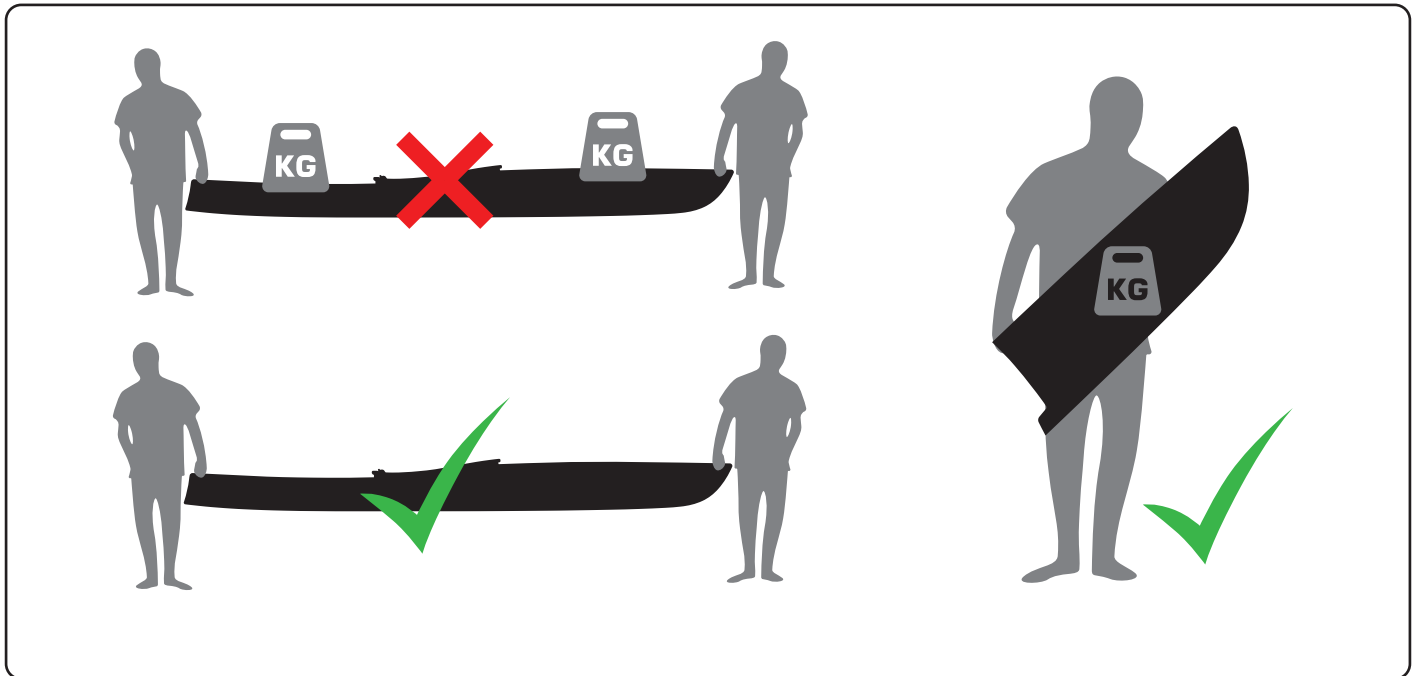

## Transport and space-saving storage

- Stow the bow turned on its side in the cockpit
- Assemble the second cockpit in opposite directions

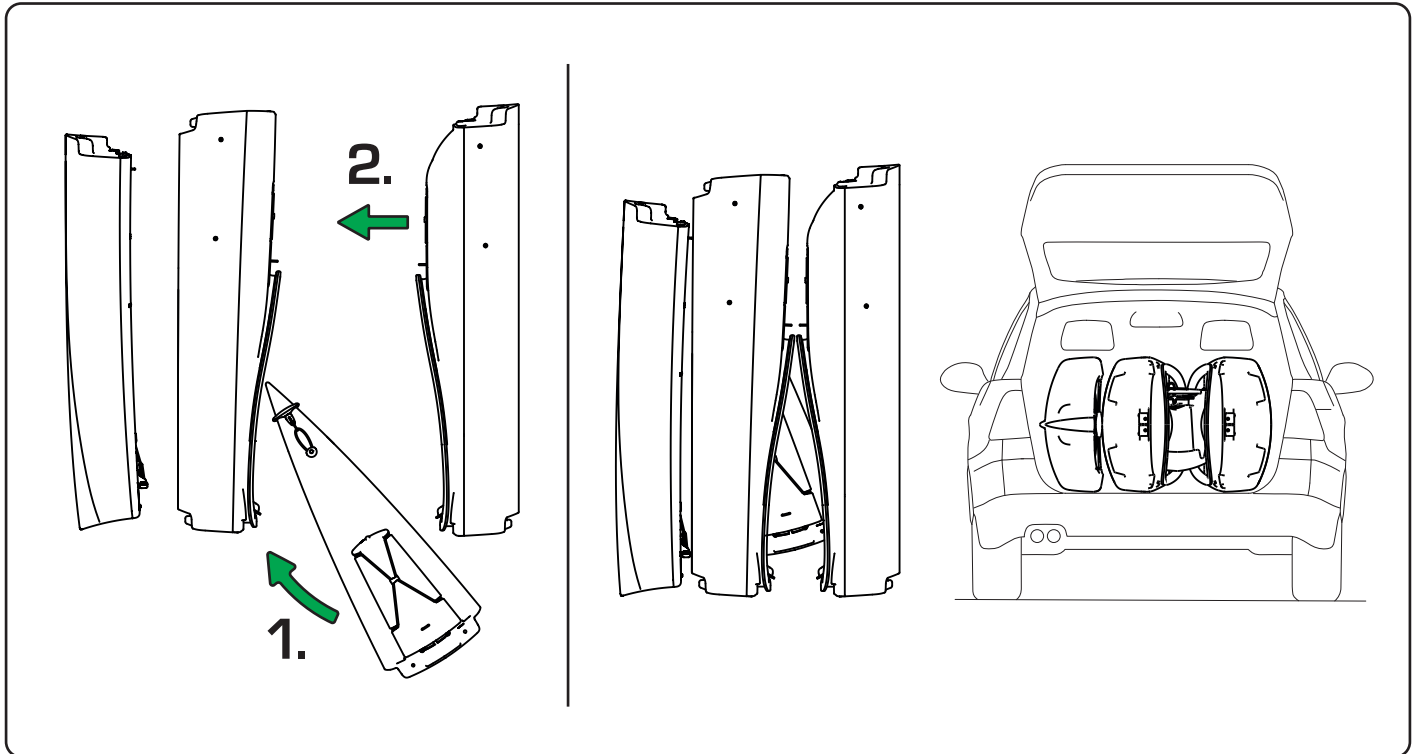

## Proper use of a kayak cart

- In general: never transport when loaded, always tighten the tensioning mechanism and ensure that it is adequately lashed to the kayak trolley (tension belts)
- Solo: fix the cart directly behind the cockpit hatch under the rear section
- Tandem: store the bow in the front cockpit, fix the car in the middle under the front cockpit, use the handle on the stern

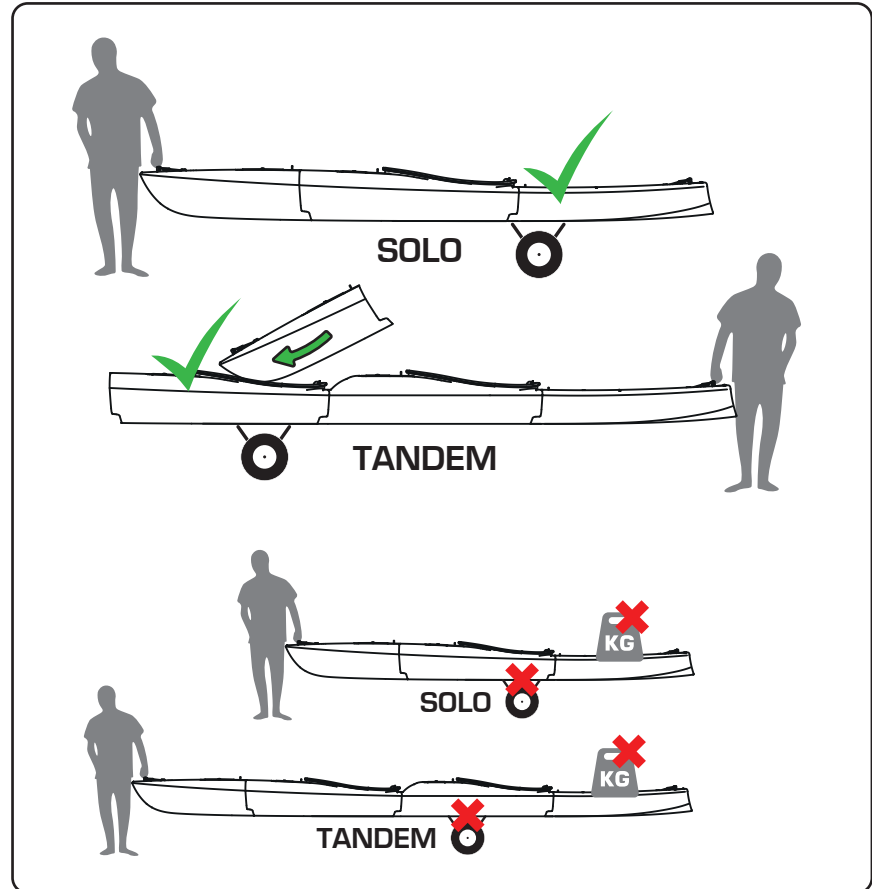

## Storage

- Despite high-quality UV protection, do not store the boat outdoors permanently
- Thanks to the modular design, it is always problem-free and space-saving in the basement, garage or even covered on the balcony

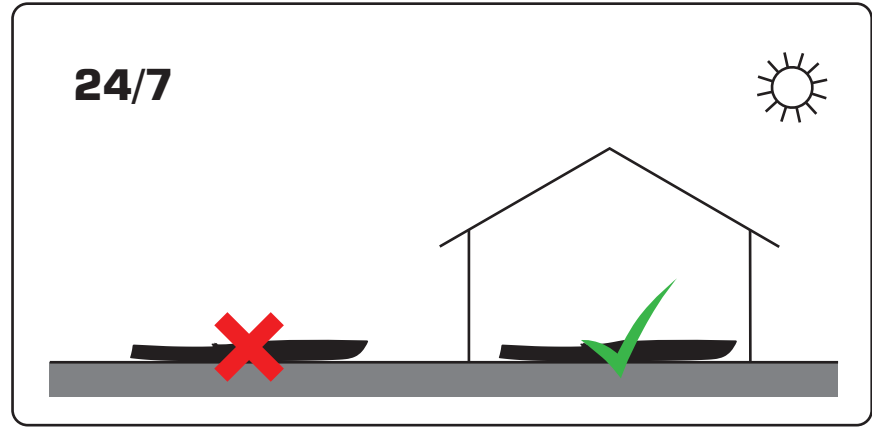

## Paddling in the sea

Your boat is ready for use laid out in salt water. All components are seawater proof. For a properly function of all components the boat need to rinse thoroughly with fresh water after each use.

This applies in particular to the locking mechanism and all moving parts.

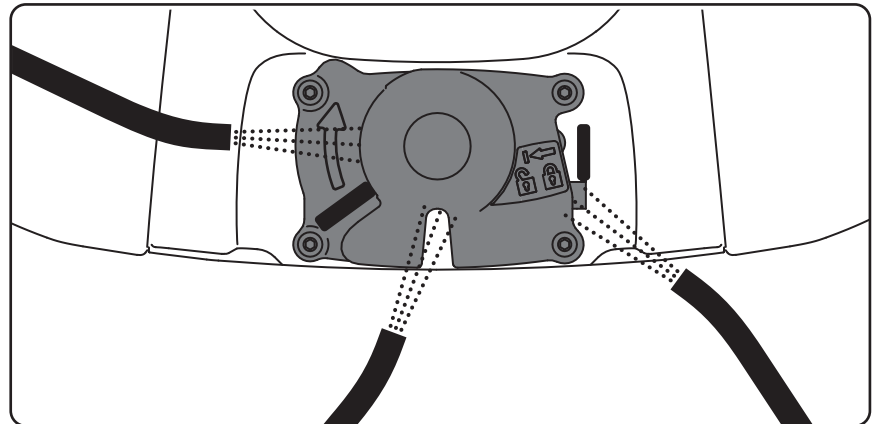



# KAYAK



*INNOVATIONS*

[www.kayak-innovations.com](http://www.kayak-innovations.com)

